



# hunter

F I L L I N G   S Y S T E M S

## SERIES 2400 FILL/SEAL/LID MACHINES

- ⌚ Available in 2, 3 or 4 lane indexing conveyor for filling, sealing and lidding of tubs.
- ⌚ Round and rectangular tubs up to 150.0mm across may be accommodated, up to 1kg capacity.
- ⌚ Up to 240 tubs/min filling and lidding. Up to 120 tubs/min filling and heat seal membranes.
- ⌚ Microprocessor (PLC) control of all functions ensures exceptional reliability.
- ⌚ System often incorporates multiple head Hunter volumetric fillers (Series 500).
- ⌚ Optional bottom-up fill, container lift at 2 filling stations can be provided.
- ⌚ Standard no container/no fill and no container/no lid or foil feature.
- ⌚ Safety guarding and interlocks to the appropriate standards.
- ⌚ Change parts available for different sized containers and lids.
- ⌚ Ejection of tub to optional out-feed conveyor and collating table.

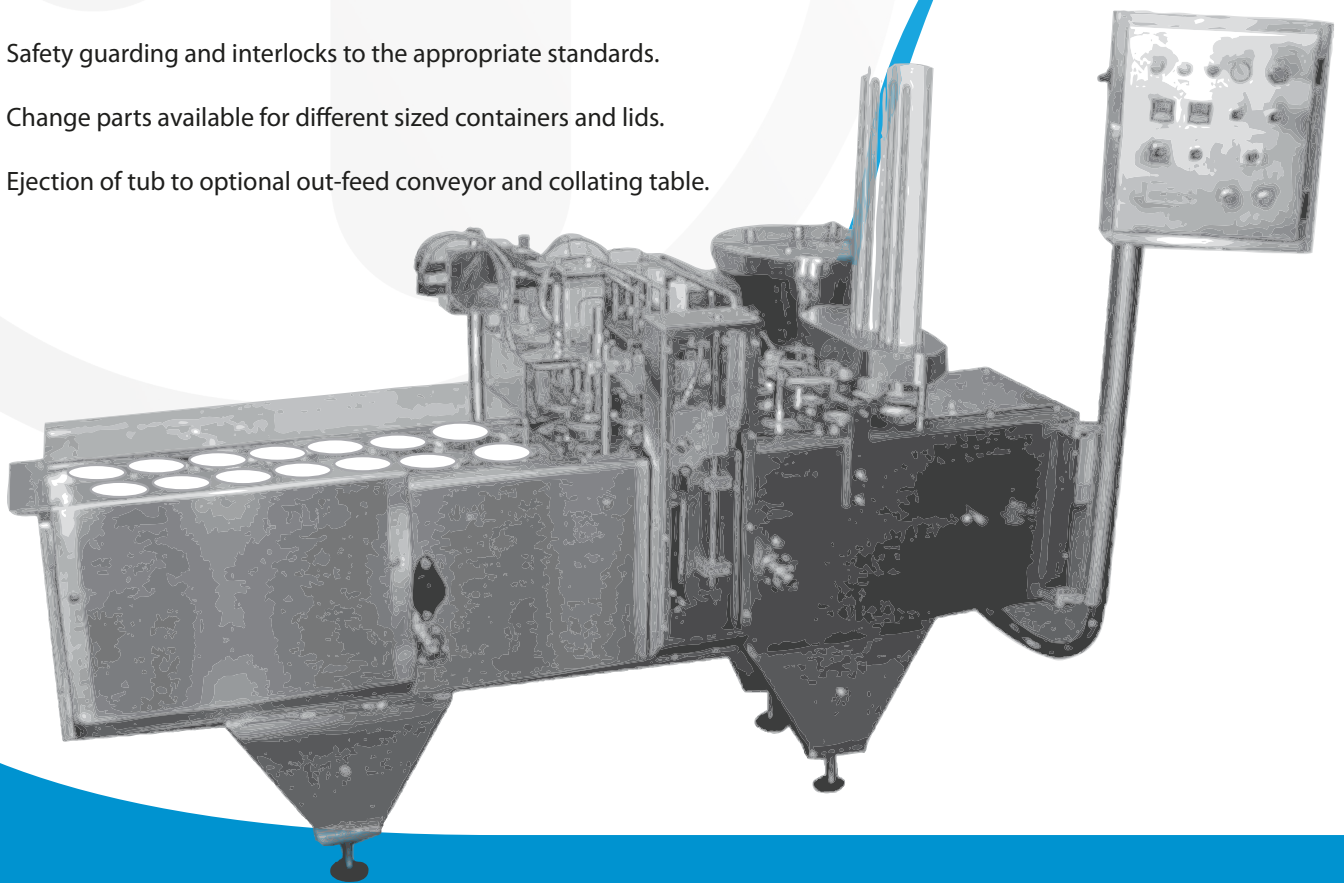

F I L L E D   W I T H   E X P E R I E N C E

### General information

Fully automatic (in line) series filling and lidding systems are designed to handle a wide range of stackable (round/rectangular) tubs, general up to 1kg/1litre capacity. Containers up to 150.0mm across may be accommodated. Available in single, dual or four lane configuration, the system is capable of up to 50 cycles per minute, enabling outputs up to 200 containers per minute on four track machines depending on product type and container size.

### Specifications

Construction is generally corrosion resistant. Type 304 stainless steel is used for all framework, external sheathing and control enclosures. Type 316 stainless steel is used for product contact parts on the filling head. Precise container positioning is effected by a robust mechanical indexing system driven by an electronically controlled motor with overload protection. Speed is infinitely variable within the range of the system. Container and lid handling functions are cam operated with some pneumatic assistance. Systems for liquid or semi-liquid products generally incorporate a pneumatically operated volumetric (piston type) filler – with bottom-up fill if necessary.

Microprocessor (PLC) control of all functions ensures exceptional reliability and, together with numerous solid state sensing devices, provides many interlocks and safeguards including the standard no container/no fill and no container/no lid features on all machines.

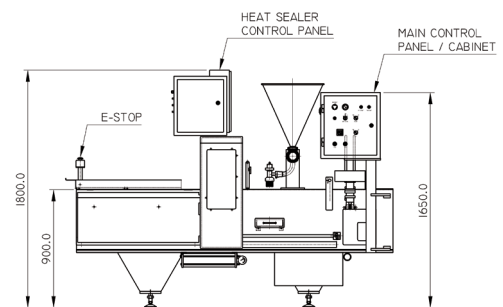
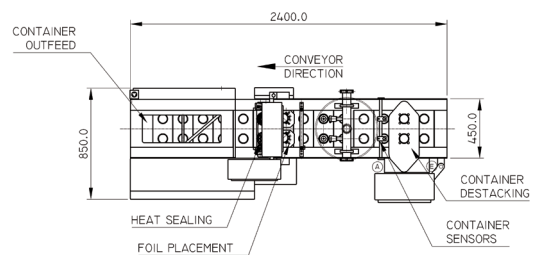

- (A) COMPRESSED AIR CONNECTION
- (E) 230V AC ELECTRICAL CONNECTION

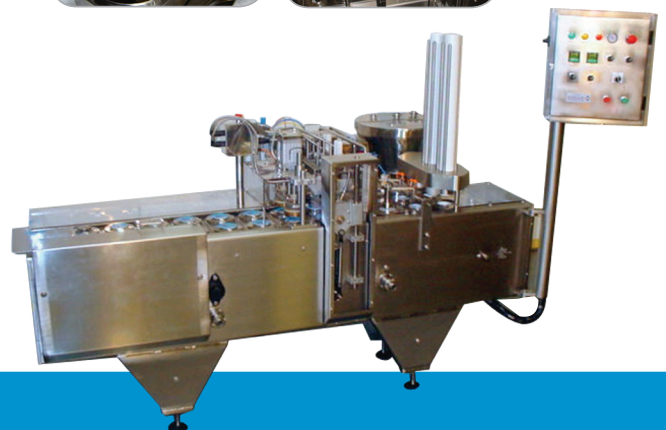

**EXAMPLES OF PRODUCT CURRENTLY PACKED BY HUNTER FILLING SYSTEMS SERIES 2400:** Butter, cheese, cosmetics, alcohol, condiments, essential oils, medicines, toiletries, lip balms, sauces, toppings and flavouring, paints, adhesives, waxes.