



hunter

F I L L I N G S Y S T E M S

SERIES 1200 FILLING MACHINES

- ⑤ Bulk filling system for accurate filling of liquid products into jerry cans, drums, IBC's.
- ⑤ Gravimetric (fill by weight on scales) or flow meter control for measuring the fill.
- ⑤ Top fill or controlled sub-surface filling options with fixed or pantograph nozzle mechanism.
- ⑤ Able to fill 4 drums on a pallet with disc brakes on pivot points during fill cycle.
- ⑤ Output up to 10 tonnes (50 x 200 litre containers) per hour.
- ⑤ Two stage product shut off for maximum accuracy.
- ⑤ A range of shut off nozzles for clean filling and drip catching outside the lance.
- ⑤ Various degrees of automation achieved with gravity roller and powered conveyor systems.
- ⑤ PLC control of all functions ensure exceptional reliability and integration with other equipment.

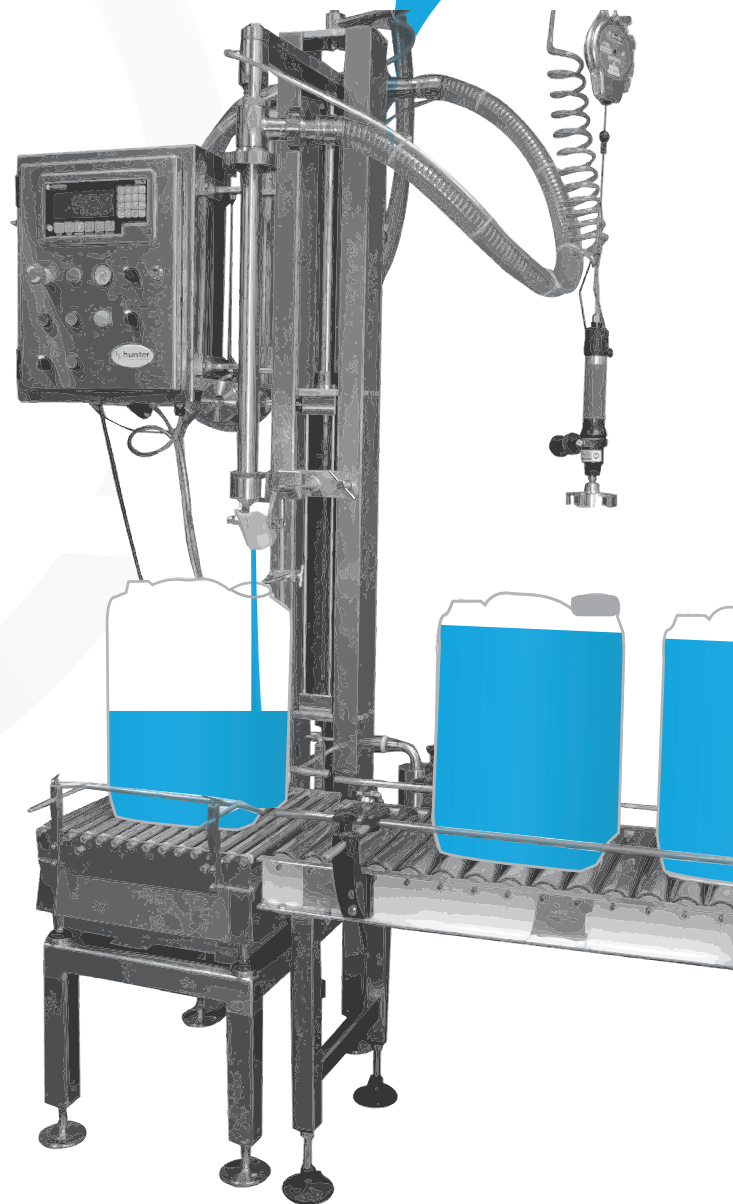

F I L L E D W I T H E X P E R I E N C E

General information

Based on commercial electronic scales the gravimetric (fill by weight) units offer accurate and rapid filling of containers up to 200 litre capacity. Two different basic models - 1200 (0.5 -20 litres) and 1201 (20 - 200 litres) - are available in either top fill or sub surface (bottom-up) fill configuration. The 1204 model is a single head gravimetric system accurately filling liquid or semi liquid products into 20-1000kg containers with an optional capacity up to 1500kg. The system facilitates twenty, 20kg jerry cans on a pallet. Product must be pumped to the machine at the required output rate.

Specifications

For smaller containers (10-30kg), a microprocessor (PLC) control of all functions ensures exceptional reliability and, together with numerous solid state sensing devices, enables a number of additional functions including options for integration with other equipment.

The basic model 1200 filler is semi-automatic, with an operator required to position the container opening under the nozzle before initiating the filling cycle. Various degrees of automation are available including gravity roller and powered conveyor systems.

For the larger 1204 model filler, product must be pumped to the machine at the required output rate – a by-pass valve may be included in the system, in which case provision must be made for disposal (return/re-process) of product while the filler is not operating. The basic model 1204 is semi-automatic with an operator required to position the nozzle over each container opening before initiating the filling cycle. Various degrees of automation are available including gravity roller and powered conveyor systems.

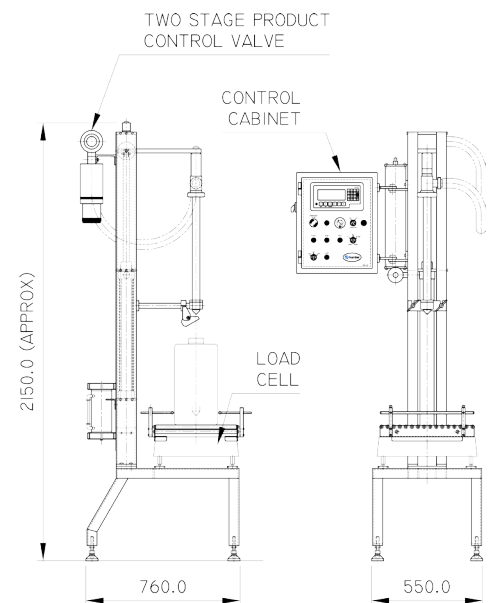

EXAMPLES OF PRODUCT CURRENTLY PACKED BY HUNTER FILLING SYSTEMS SERIES 1200: Butter, cheese, cosmetics, alcohol, condiments, essential oils, medicines, toiletries, lip balms, sauces, toppings and flavouring, paints, adhesives, waxes.